

RT/1120 Rotary Trimmer

Featured Benefits

- Opto-electric trimmer monitoring system ensures consistent production runs
- Accu-set knife adjustment system ensures maximum knife performance
- Synchronous motors for perfect alignment at high speeds
- Easy changeover & knife regrinding
- Pro-Tect knife guard system offers controlled access, thus, maintaining knife performance
- Up to 90,000 copies, cut on 2 sides, can be produced
- Variable speed knife drive ensures optimum trim quality
- Highest quality trim performance
- Low cost of operation
- Simple, easy-to-use, reliable operation
- Easily switch off one or both knives for complete production flexibility
- Long knife life



The **RT/1120 Rotary Trimmer**, available from Systems Technology, Inc., is the trimmer of the future, available now. Several unique operating features including Opto-Electric Trimmer monitoring system, Accu-set knife adjustment system, Pro-Tect knife guard system, and Variable speed knife drive make this rotary trimmer the choice for the most demanding users who require high trim quality. Products range from the high quality automotive brochures to high page count signatures on newsprint and uncoated stocks, and a whole range of finished products in between. The **RT/1120 Rotary Trimmer** has also found its home in the high speed retail insert houses running speeds in excess of 80K IPH.

The extraordinary knife life of its solid carbide, large diameter cutting surfaces sets the standard for long knife life and continues to dramatically out perform our competition using alternate knife configuration technology. In addition, the operating costs related to knife sharpening and replacements are far lower compared to these other knife technologies. And, of course, trim quality standards are the highest in the industry, from the first signature to whenever the knife is ultimately re-sharpened.

Regardless of your application, the **RT/1120 Rotary Trimmer** will deliver the trim quality you require at the lowest operating cost, while delivering the greatest level of reliability and operability available in today's printing world.

The **RT/1120 Rotary Trimmer** and its complementary line of integrated 3- and 4-knife trimmers, stacked trimmers, and center trim units, as well as specialty conveying equipment, overhead trapped-belt conveyors, and stream separator deservers is produced to the most exacting manufacturing standards and technical specifications by its manufacturer in Vienna, Austria.

The **RT/1120's** sales, service, and after-market parts are provided exclusively in North America by STI.

Systems Technology Inc.

1351 E. Riverview Dr. • San Bernardino • CA 92408 USA • Tel: 909.799.9950 • Fax: 909.796.8297

www.systems-technology-inc.com

RT/1120 Rotary Trimmer

TECHNICAL SPECIFICATIONS

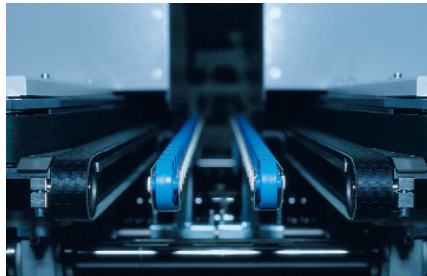

Synchronous motors allow perfect alignment at high speeds.



Optimum knife configuration for your range of applications.

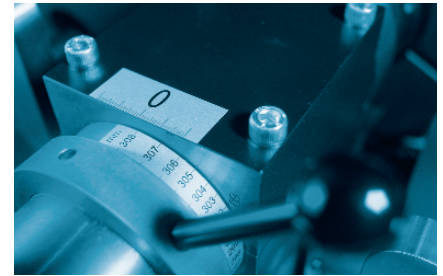

State-of-the art technology with superior quality over comparable products.

Product:	Minimum	Maximum	
Untrimmed Product Dim "A"	100 mm (3.94")	550 mm (21.65")	
Untrimmed Product Dim "B"	100 mm (3.94")	550 mm (21.65")	
Trimmed Product Dim "A"	90 mm (3.54")	490 mm (19.29")	
Product Waste	3 mm (0.12")	60 mm (2.36")	
Product Pagation	Total thickness 15 mm. max. (.59")		
Product alignment	By vibrating belts adjustable during operation		
Machine:			
Operating Speed (Adjustable)	0-120 m/min (60 m/min @ 50Hz)		
Main Drive	1x 1.5kW (AC)		
Regulated Blade Drive	2x 2.2kW (AC)		
Alignment Drive	2x 120W (AC)		
Slide Adjustment	Four hand wheels for alignment & knife slides, adjustable from both sides		
Machine Operation	Two controllers each left or right, adjustable from both sides		
Lower Blade	ø150 mm (ø5.91")		
Upper Blade	Minimum: ø300 mm (ø11.81")	Maximum: ø308 mm (ø12.13")	
Waste Extraction Slot	2x ø100 mm (ø3.94")		
Waste Extraction Unit	To be provided by customer		
Extraction Output (Per Slot)	900 m ³ /hr, 1960 Pa, 30m/sec (530cfm, 0.28psi, 98ft/sec)		
Input Power	230VAC, 3Ph, N, PE 30 amp		
Air Requirement	Minimal air consumption, 5bar-9bar		
Noise Level	84 dB(A)		
Weight	2.350 kg (1,650 lb)		
Paint Color	RAL 7035 (Light Grey)		

CRITICAL DIMENSIONS

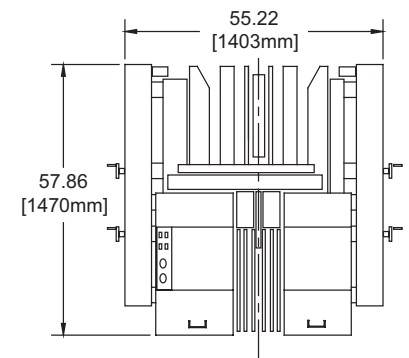
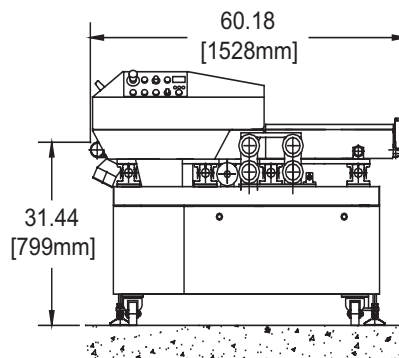
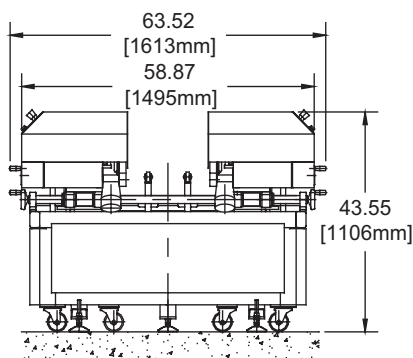

STI reserves the right to change specifications without notice. Covered by foreign patents and/or patents applied for.