

## **SuperFeeder™ -XA**

### **Featured Benefits:**

- Control of product pile feed height
- Reduced make-ready time
- Steadier and faster running speeds
- Easy conversion from bricks to logs with optional log extension conveyor
- Less training required for loading personnel
- Reduced manning allows redeployment of existing personnel
- Increase “nets” by 10-30% and decrease stops
- Significantly reduce waste
- Cut worker’s compensation claims costs
- Lower operating and maintenance costs

The new **SuperFeeder™-XA** unit has been specifically designed to interface with the new Goss International H211 and H311 horizontal pockets for the Goss International 870 and SP1000 series saddle stitchers, the Heidelberg ST400 saddle stitcher equipped with “TALW” pockets, or other flat pile pockets that use a slightly angled delivery. The high speed signature acceleration and jogging module positioned at the discharge of the machine delivers high quality, well separated and conditioned signatures to the pocket for the most reliable feeding. The simplicity of operation and proven performance on the lightest weight products makes this **SuperFeeder-XA** the first choice of bindery operators and management personnel world wide.

The **SuperFeeder-XA** is built upon the proven performance of the SuperFeeder hopper loaders originally introduced for conventional flat pile pockets. The SuperFeeder series hopper loaders have become the industry standard for automatically feeding signatures into flat pile pockets. Make-ready is shortened by the one-piece ramp conveyor side guide and quick-adjustable scissors mainframe side-guide. Height adjustment to meet varying pocket elevations is simplified and is easily adjusted by the operator. The sloped main feed conveyor allows easy placement of signatures, spine down, with little or no hand jogging required. The continuous 3-belt signature delivery system improves the ability to handle smaller products. The single, continuously-arched delivery conveyor provides for better shingling control and improves the ability to handle stiffer closed-head products.



### **Systems Technology Inc.**

1351 E. Riverview Dr. • San Bernardino • CA 92408 USA • Tel: 909.799.9950 • Fax: 909.796.8297  
[www.systems-technology-inc.com](http://www.systems-technology-inc.com)

## TECHNICAL SPECIFICATIONS

	Specifications	SuperFeeder-XA	SuperFeeder-XA-Tab
Product sizes:	Head to foot minimum Head to foot maximum Spine to open edge minimum Spine to open edge maximum	6.00 inches (152mm) 12.50 inches (318mm) 3.00 inches (76mm) 12.00 inches (305mm)	6.00 inches (152mm) 19.00 inches (482mm) 3.00 inches (76mm) 12.00 inches (305 mm)
Pagination: Paper types:	2pgs.-64pgs., single stock, cards, perfume strips, & other gimmicks. Offset, gravure, newsprint, coated & uncoated, directory, envelopes, & in-line finish products.		
<b>Machine:</b>			
Feeding speed:		20,000 products per hour	20,000 products per hours
Input power:		110VAC, 1Ph, 7.3A, 50/60Hz 230VAC, 1Ph, 3.8A, 50/60Hz 230VAC, 3Ph, 2.2A, 50/60 Hz	110VAC, 1Ph, 7.3A, 50/60 Hz 230VAC, 1Ph, 3.8A, 50/60 Hz 230VAC, 3Ph, 2.2A, 50/60 Hz
	Pocket pile control height: Pocket loading height minimum: Pocket loading height maximum:	+/- 1/4 inch (6.5 mm) 35 inch (889 mm) 39-1/2 inch (1,003 mm) max.	+/- 1/4 inch (6.5 mm) 35 inch (889 mm) 39-1/2 inch (1,003 mm) max.
	Overall width main feed section: Overall width accelerator assembly: Overall length: Overall height:	14 inches (355 mm) 19 inches (483 mm) 113.5 inches (2,883 mm) 65 inches (1,651 mm)	14 inches (355 mm) 19 inches (483 mm) 113.5 inches (2,883 mm) 65 inches (1,651 mm)
	Air Requirement:	80psig (6 bar) 13 cfm	80psig (6 bar) 13 cfm
Optional Log Extension Conveyors:		6 ft. (1,830 cm) to 10 ft. sizes (3,018 cm) available.	



Signatures are corrugated to ensure even light-weight stock is well jogged in the pocket.

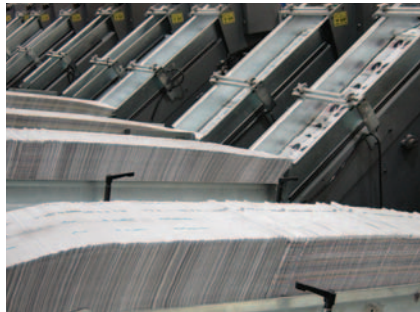

Signatures are singulated, so operators do not have to spend the time jogging, thereby, reducing the risk of repetitive motion injuries.



SuperFeeder-XA is available in a version that has an adjustable angle on the load conveyor to best suit the products being run.

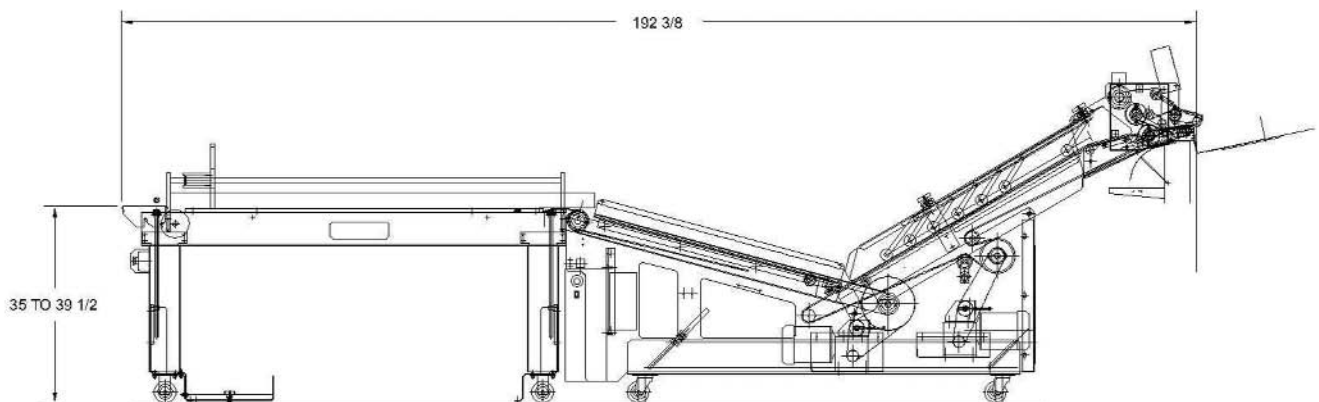

STI reserves the right to change specifications without notice.

This equipment manufactured under one or more of the following U.S. Patents: 6,017,028

Also covered by foreign patents and patents applied for.